



# INTRODUCTION FLAT HEAT PIPE (MG-FHP)

**EMAIL**

info@mgitaly.it

**WEBSITE**

www.mgitaly.it

**TELEFONO**

+39 055 91 24 139

# MG-FHP → FLAT MICRO HEAT PIPE

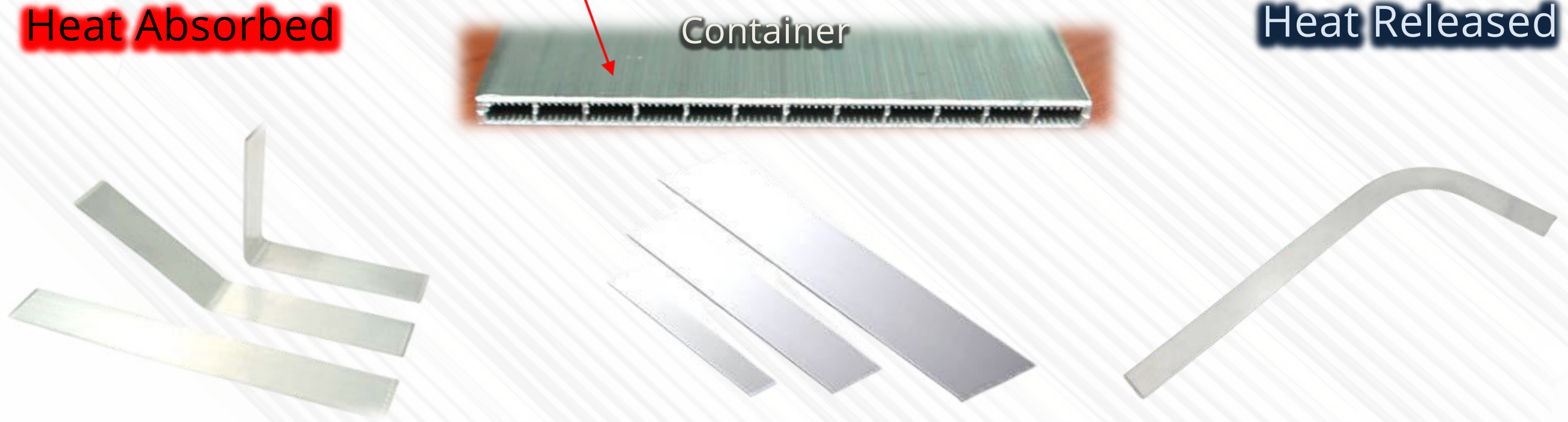
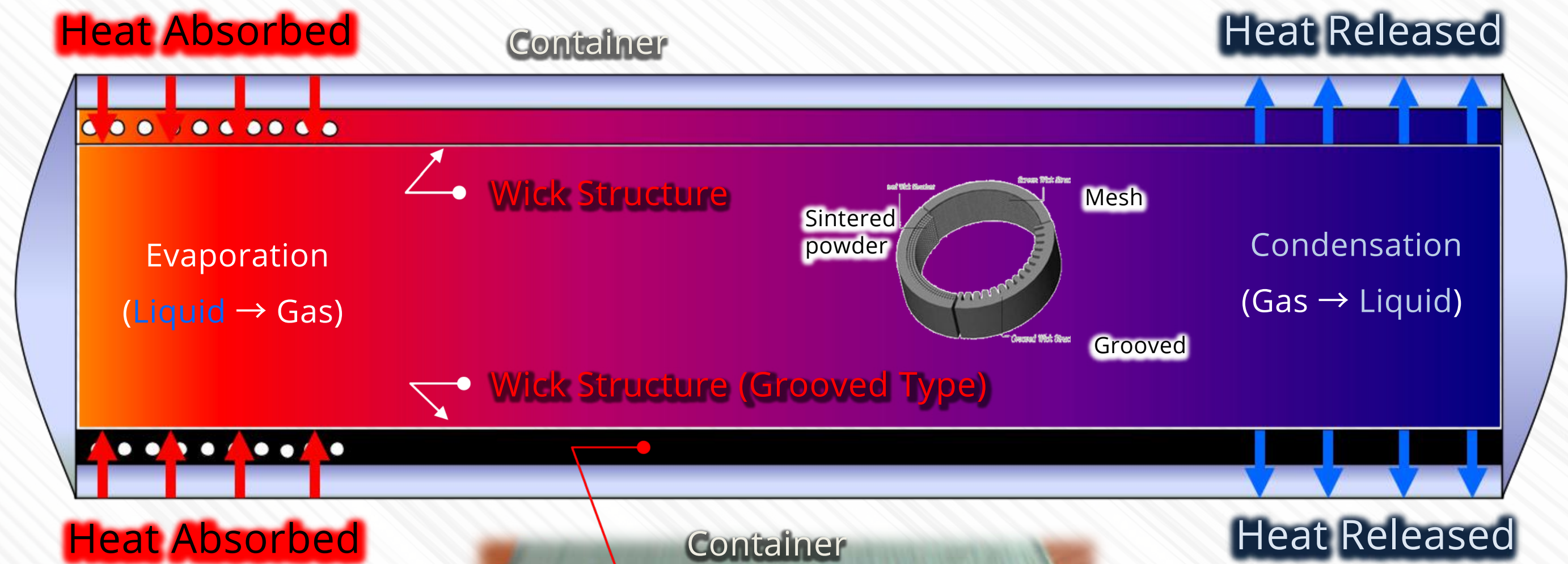

# MG-FHP → WORKING MECHANISM

Phase Change Technology : **Conduction & Convection Heat Transfer Mechanism** Working Process :

1. Heat applied to the evaporator section by an external heat source is conducted through the MG-FHP wall.
2. Working fluids are vaporized then, working fluids through the vapor section to the condenser section.
3. Then releasing its latent heat of vaporization to the external cooler module of condenser section.
4. And working fluids return to the evaporator section in the liquid phase by the capillary pressure or gravitational force.

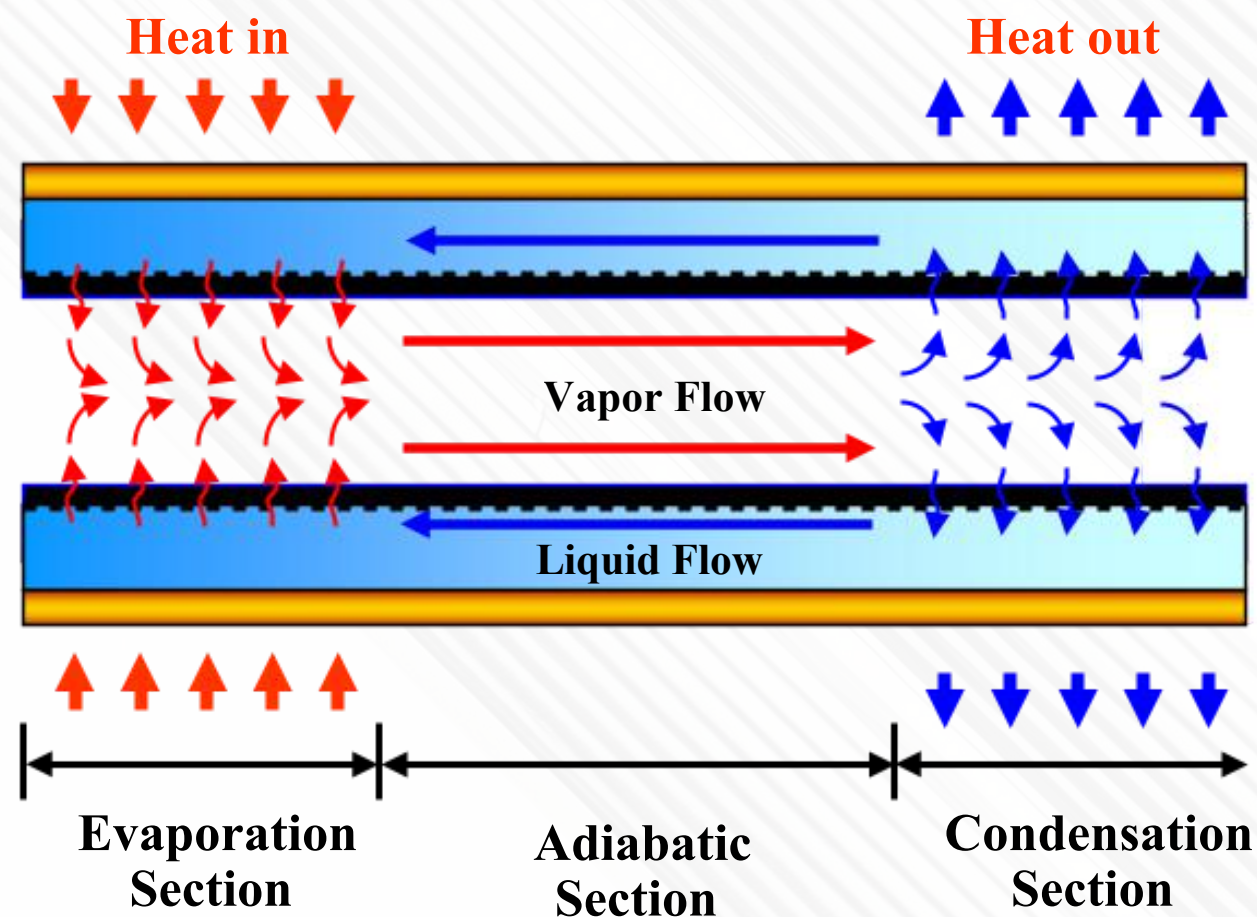

< Working Mechanism of MG-FHP >

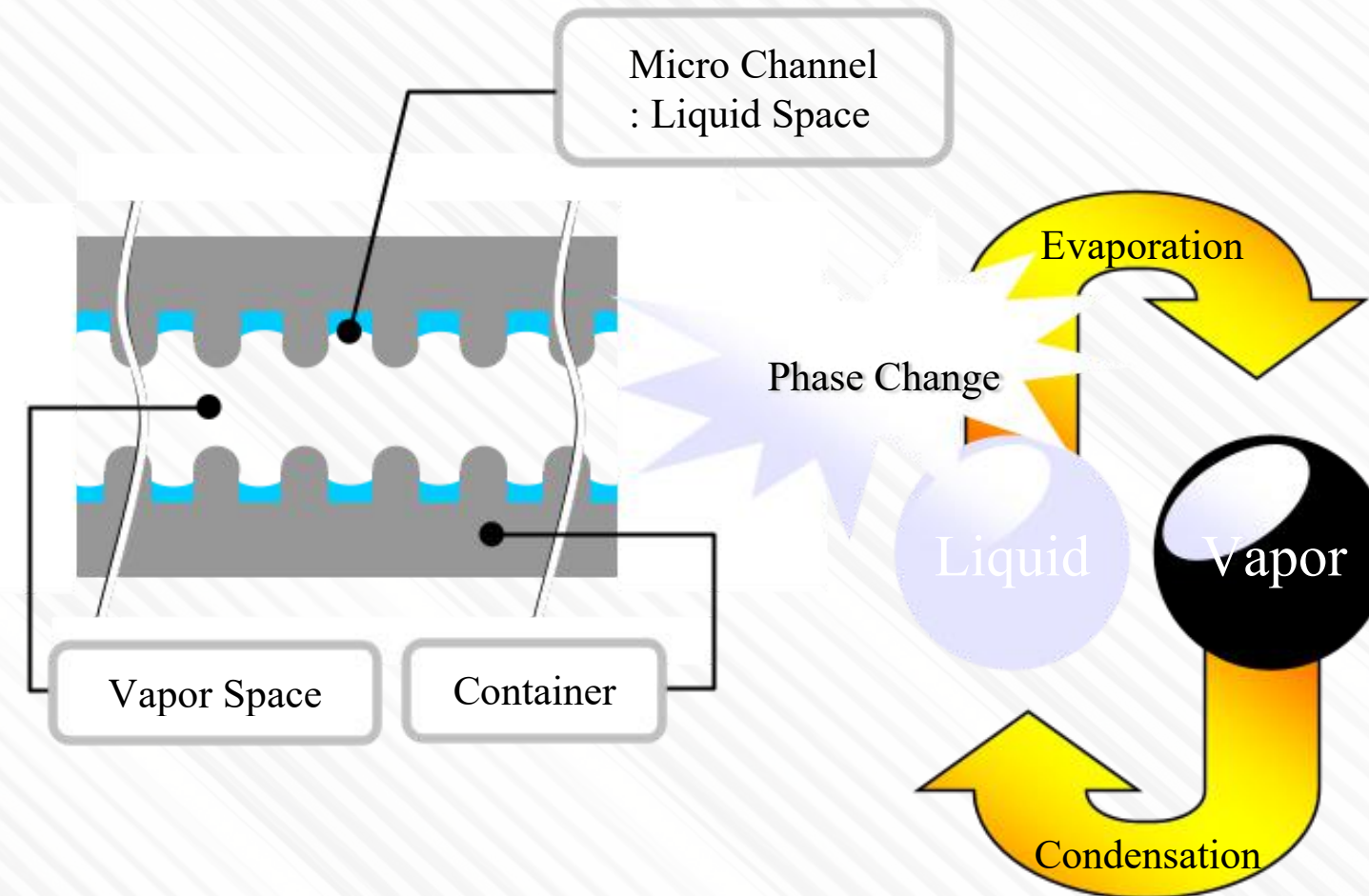

< Cross Sectional Area of MG-FHP >

# MG-FHP → UNIQUE CHARACTERISTIC

## A. Thermal Responsibility

Unsteady State (=Transient)

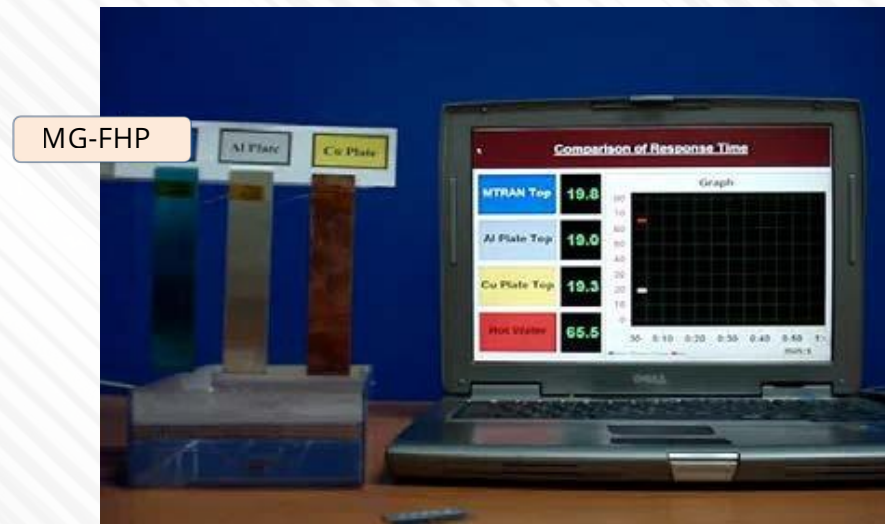

※ MG-FHP, Cu Plate and Al Plate

Dimension : T-1.2t, W-23mm, L-125mm

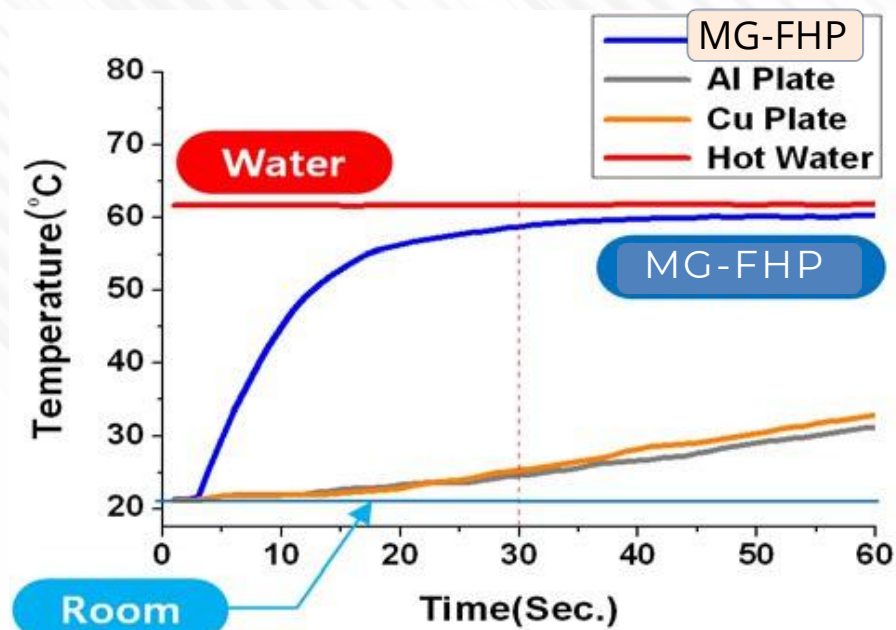

Superb Fastest Heat Transfer Media

## B. Uniform Thermal Equilibrium

Steady State (=Saturation)

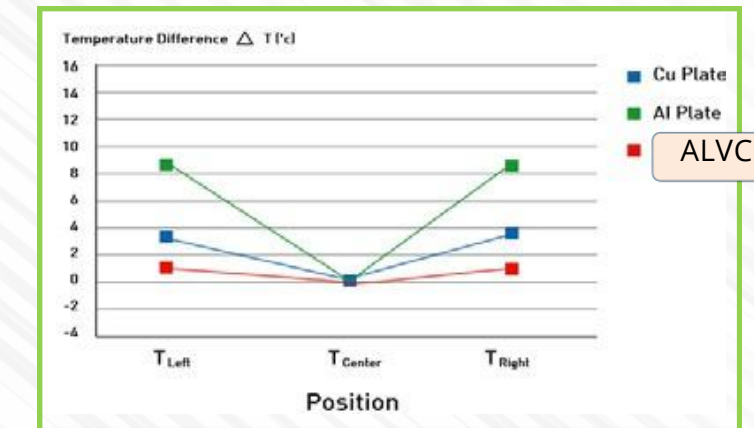
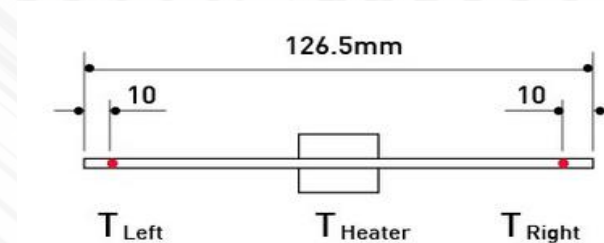

Uniform Temperature →  $T_{Heater} - T_{Side} \leq 1^\circ C$

## C. High Heat Treatment Capacity

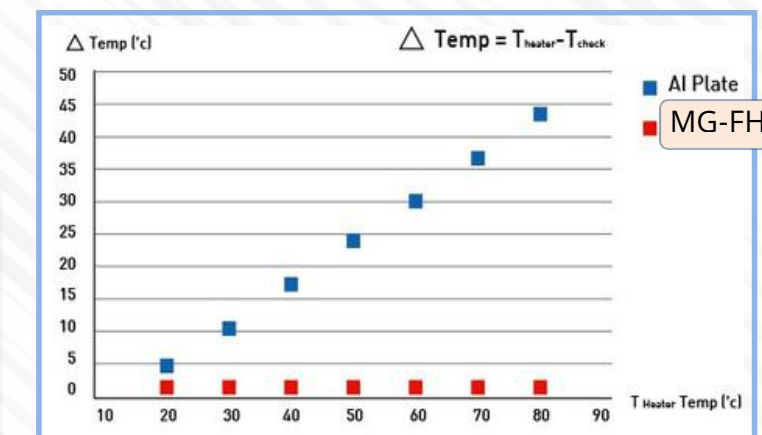

Even if the temperature is increased, It maintains a small temperature difference.

# MG-FHP → LOW THERMAL RESISTANCE (COMPARISON)

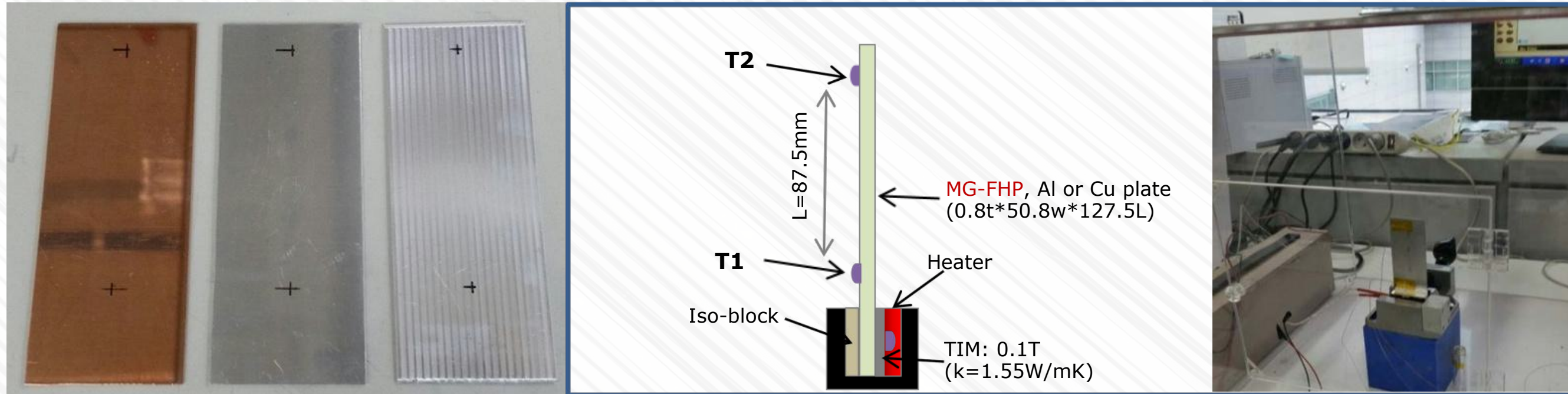

Material		MG-FHP	Al plate	Cu plate
Size(mm)		50.8W x 127.5L x 0.8T		
Weight(g)		10.8	13.7	46.1
$\Delta T$ (T1-T2)	10W	1.2°C	13.3°C	9.7°C

Slim MG-FHP has light weight compare to Aluminum and Copper at same size

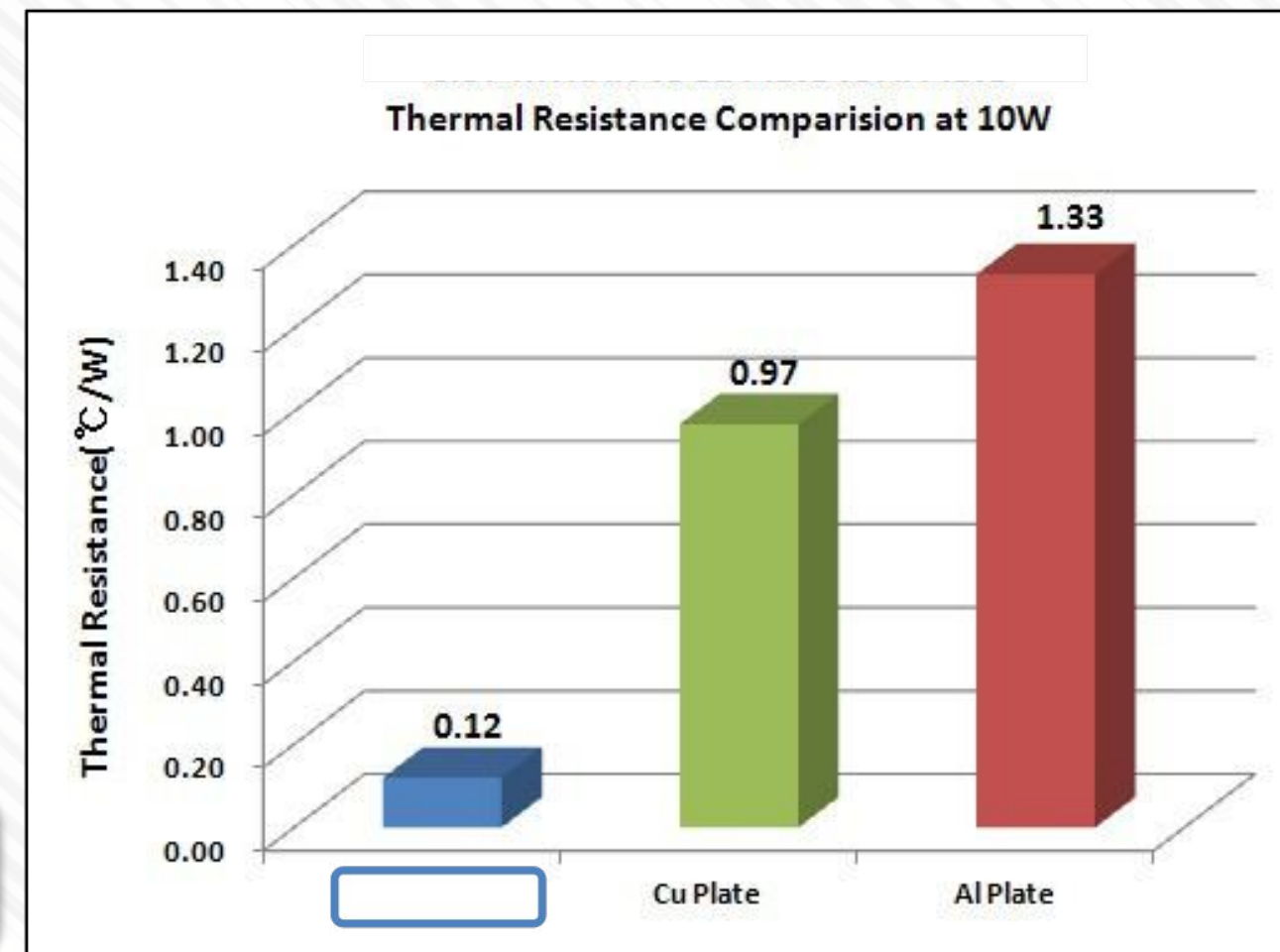

# MG-FHP → UNIQUE CHARACTERISTIC



## ■ Cost-effective Material: Aluminum

### ■ Ultra Thin and Light

- Thickness: 1.5~6.0mm - Weight: only 1/3~1/2 of Solid Aluminum

### ■ Superior Thermal Performance

- Thermal Conductivity up to 10,000W/mK -  
 $Q_{\max}$  : up to 250 W/unit  
-  $T (T_{\text{evap}} - T_{\text{cond}})$  : lower than 1°C

### ■ Planner Bending Ability

### ■ Wide Width

- Normal Width :  $\leq 30\text{mm}$

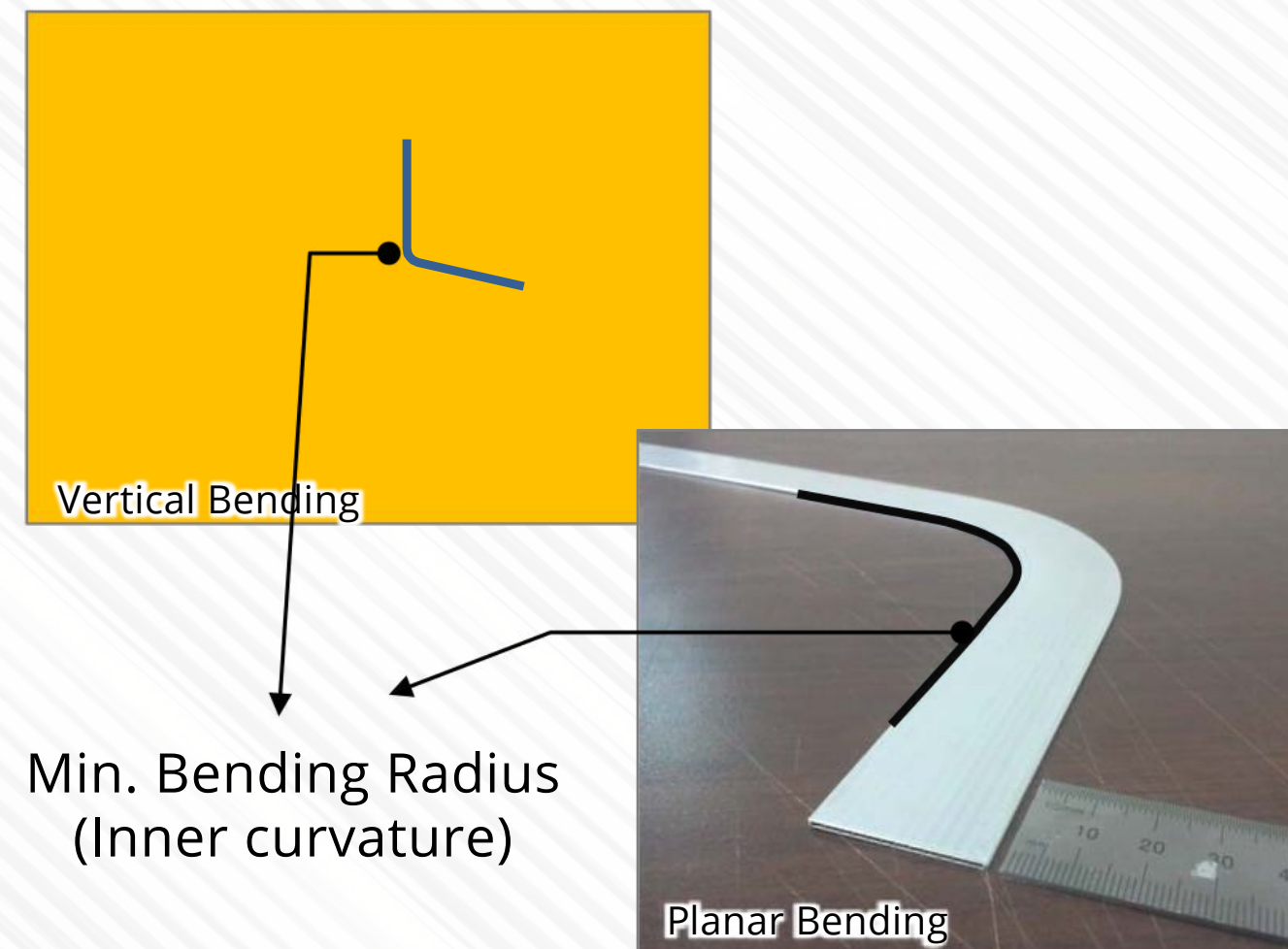

# MG-FHP → BASIC SPECIFICATIONS

## MG-FHP = Aluminum Vapor Chamber

ITEM	Description
Material of Container	3003/1050/6061
Wick Structure	Grooved Wick
Working Fluids	Acetone etc.
Typical Thermal Resistance	< 0.4°C/W (Straight, No Bending)
Operating Inclination( $\theta$ )	0 ~ 90°
Leakage Temperature	~190°C (Normal Thickness)
Vertical bending angle (Min)	2x Thickness
Planner bending angle (Min)	R35
Planner bending width (Min)	≤30mm
Theoretical life	17 years
Flatness (Min)	0.1mm
Withstand pressure	550psi Nickel plating, anodizing, brushing, polishing
Available surface treatment	
Installation method:	① low temperature solder paste welding ② epoxy resin bonding

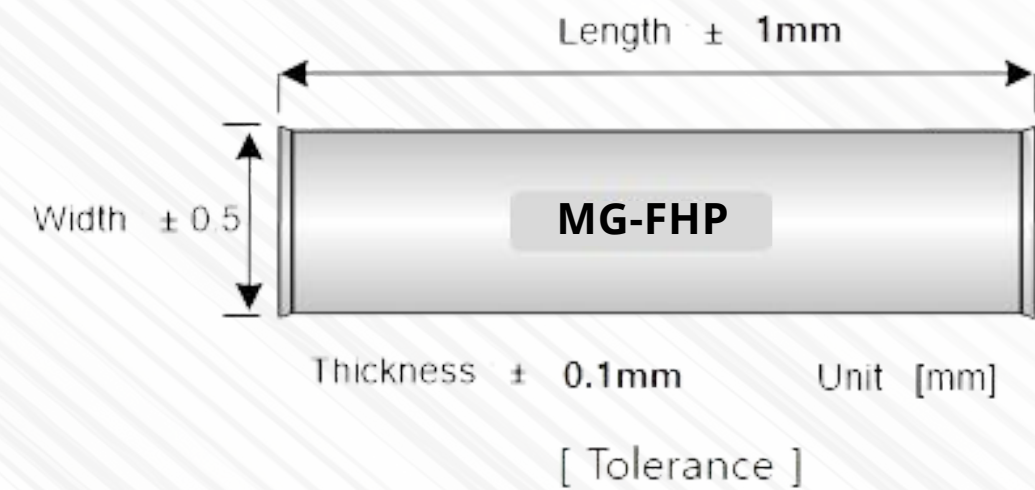

# MG-FHP → SPECIFICATIONS

## MG-FHP thermal conductivity

Thermal conductivity (W/mK)			
$k_x$	5,000	<div style="display: flex; justify-content: space-around;"> <span>● Heat upside</span> <span>● Heat downside</span> </div> <div style="display: flex; justify-content: space-around;"> <span>Invalidation</span> <span>10,000</span> </div>	5,000
$K_y$	3,000	3,000	3,000
$K_z$	5,000	5,000	5,000

### NOTE:

1. Different installation directions have different thermal conductivity.
2. The heat source must be at the bottom and the condensation end must be at the top
3. Ineffective use against gravity



[Various Shape of MG-FHP]

Heater

Condensation

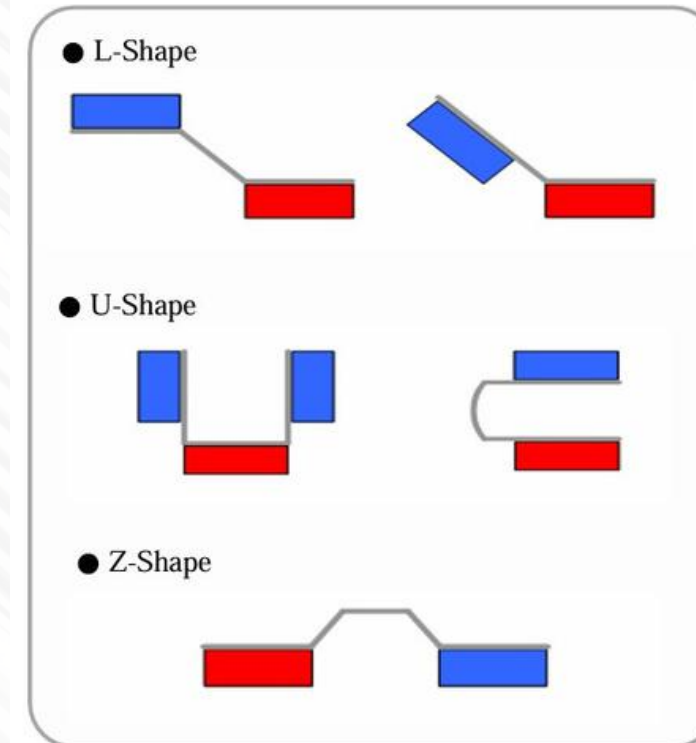

# MG-FHP → MAJOR APPLICATION FIELDS



# MG-FHP → APPLICATION ACTUAL OPERATION



# MG-FHP → APPLICATION FOR SET-TOP BOX

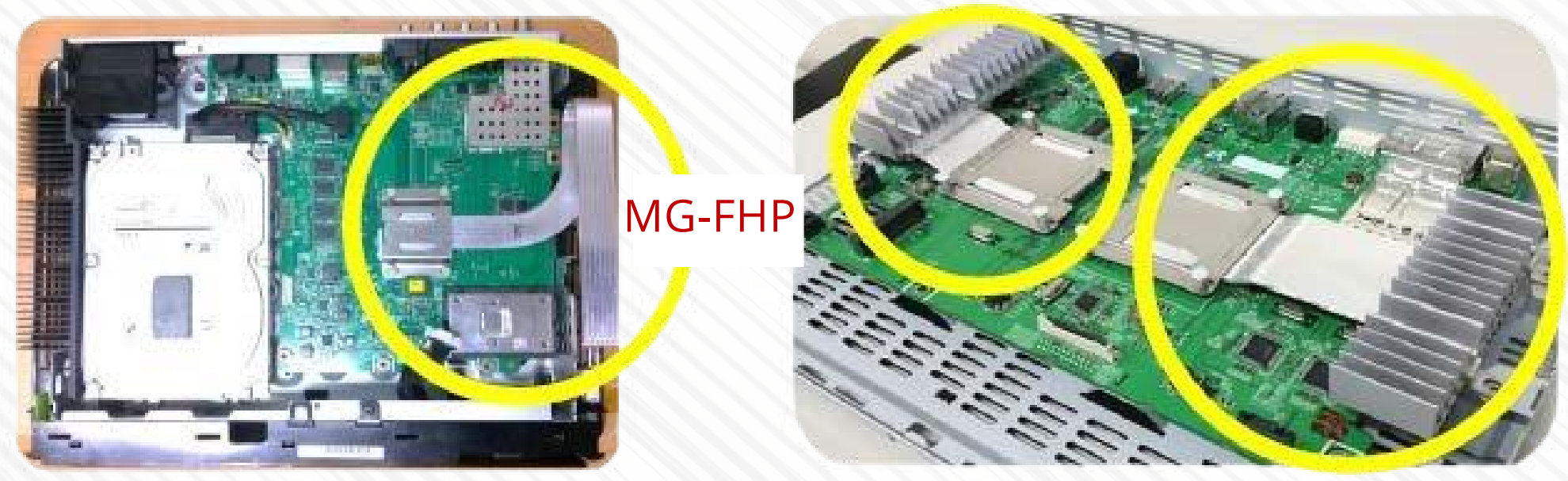

Low number of parts assembled MG-FHP module drops device temperature as well as case temperature



## MG-FHP Solution VS Cu Heat pipe Solution

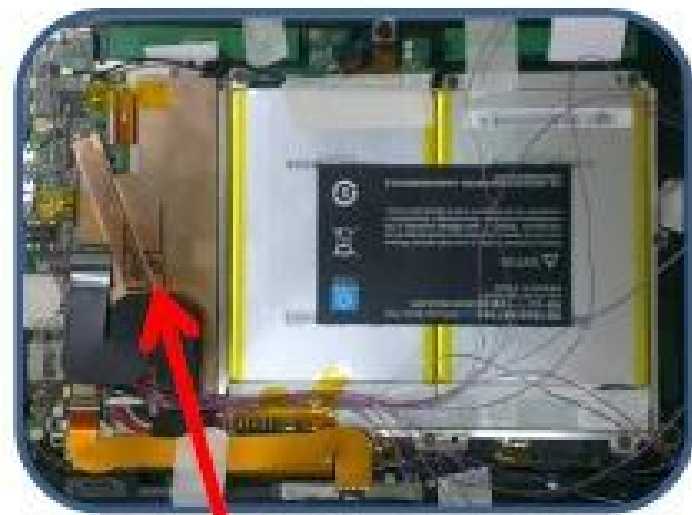

[Cu Heatpipe with Cu plate]

- ❖ CPU: Tegra 4 (6.65W)
- ❖ 3G / LTE stem memory is 2GB
- ❖ Built-in storage is 16GB
- ❖ Main camera is 13MP & Front camera is 1.2MP.
- ❖ resolution panels: WQXGA (2,560 x 1,600)
- ❖ Thickness 8.8mm
- ❖ Weight 600g
- ❖ 34Wh battery official estimate can use WiFi 8.5 hours.

	Air	CPU(1)	SKIN(13)	SKIN(14)
<b>MG-FHP Solution</b>	24.6	<b>69</b>	<b>45.8</b>	<b>34.5</b>
<b>CU Heatpipe Solution</b>	24.8	<b>88.3</b>	<b>53.5</b>	<b>36.3</b>

# MG-FHP → APPLICATION FOR TABLET ULTRA BOOK

Model	Picture	Condition	Specification
ATIV 9 Lite NT915S3G-KSQT		Total Set Power : 13.3W CPU Power : 5.64W Environment : 25 °C	OS : Window 8 (64bit) CPU : Quad-Core (1.4GHz) Memory : 4GB (DDR3 1066, on-BD) SSD : 128GB Graphic : Radeon™ HD 8250 Resolution : 1,366 X 768 Thickness : 17.4mm Weight : 1.58 kg

MG-FHP Module drops CPU temperature well as case temperature!

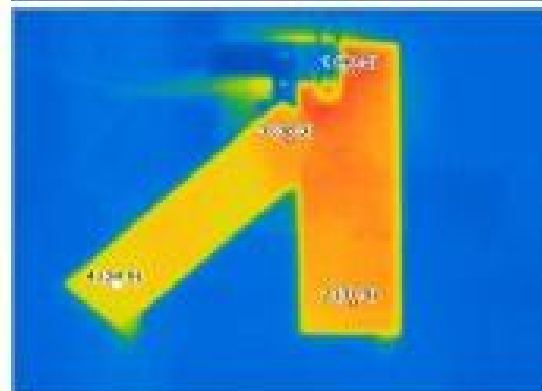
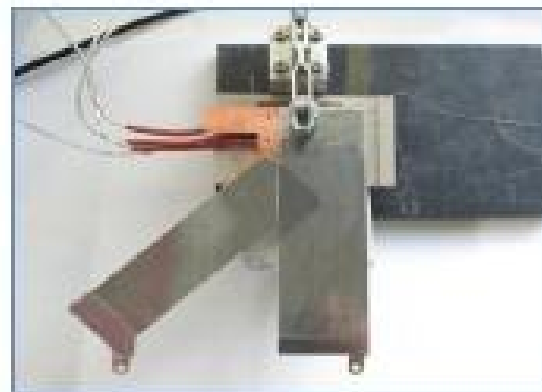

[MTRAN Solution]

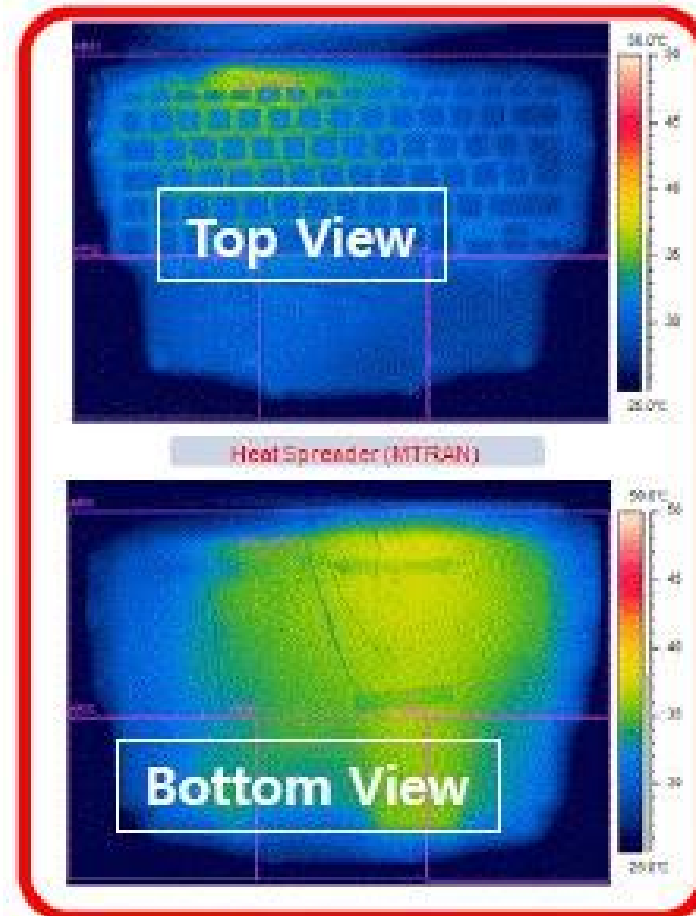

[MG-FHP solution (no fan)]

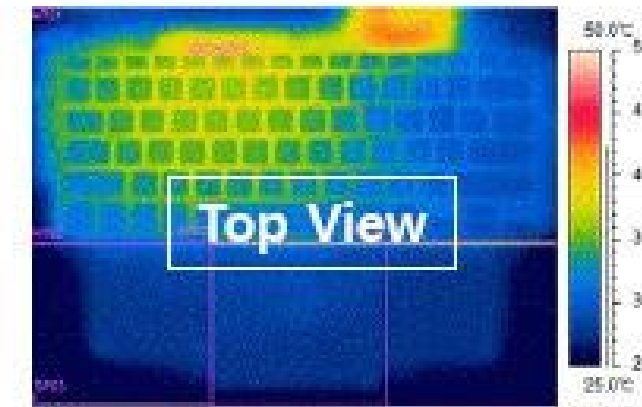

Fan Solution

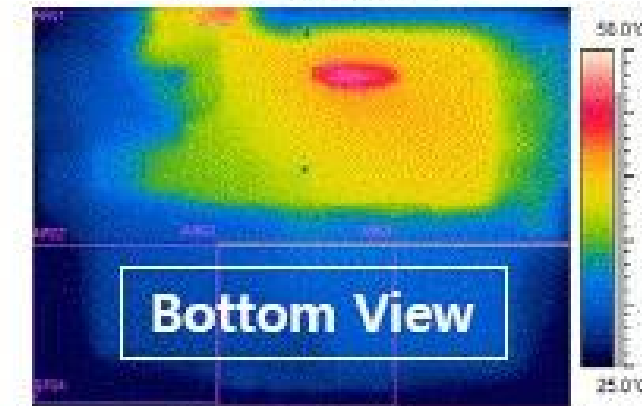

[Heat Pipe+Fan Solution]

# MG-FHP → APPLICATION FOR DISPLAY

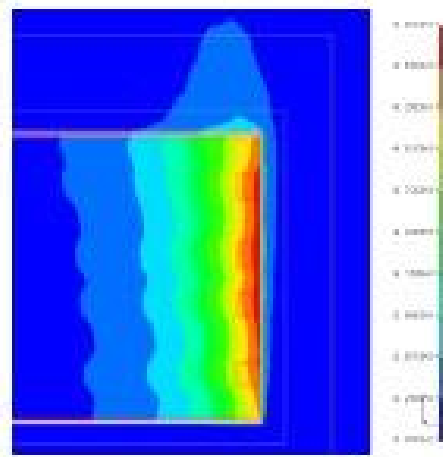

[Without MG-FHP]

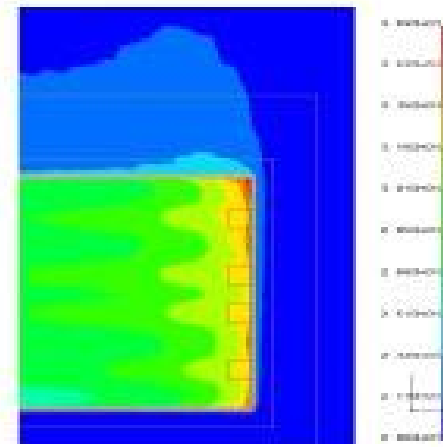

[With MG-FHP]

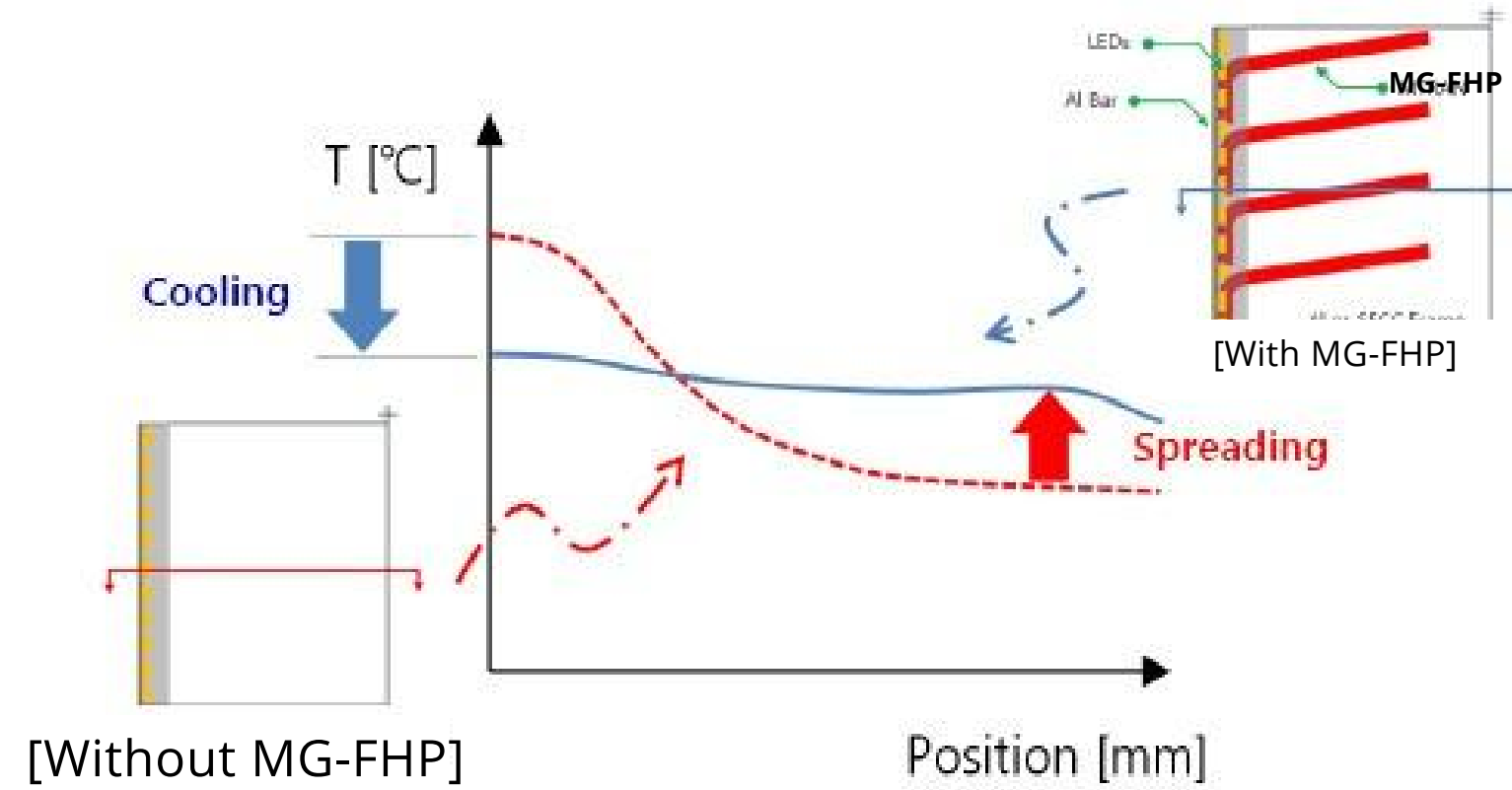

## MG-FHP Solution VS. Cu Heat pipe Solution



[MG-FHP]



[CU Heatpipe]

	Air	Light Bar	Bazel
MG-FHP Solution (Average)	25	68.8	46
CU Heatpipe Solution (Average)	25	74.1	49

# MG-FHP → APPLICATION FOR DISPLAY

## MG-FHP Solution for Blue LED TV.

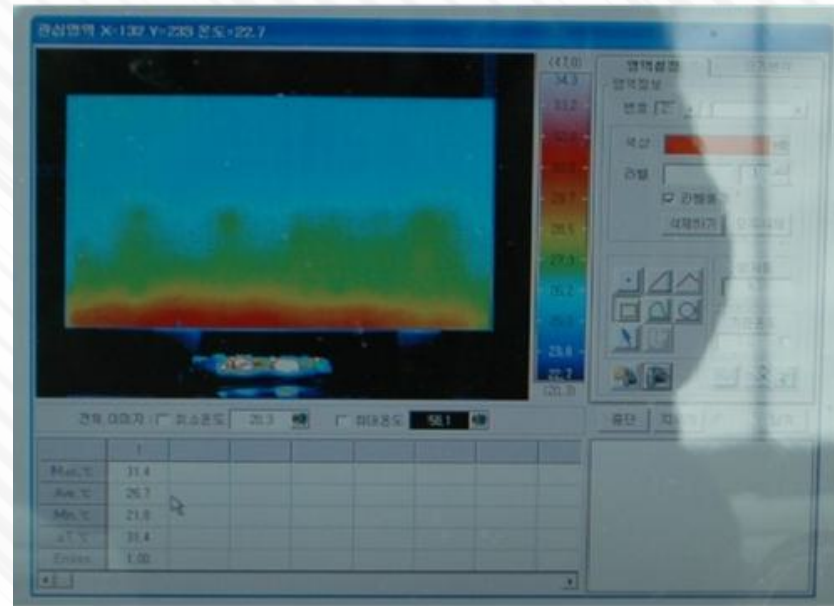

[Without MG-FHP]

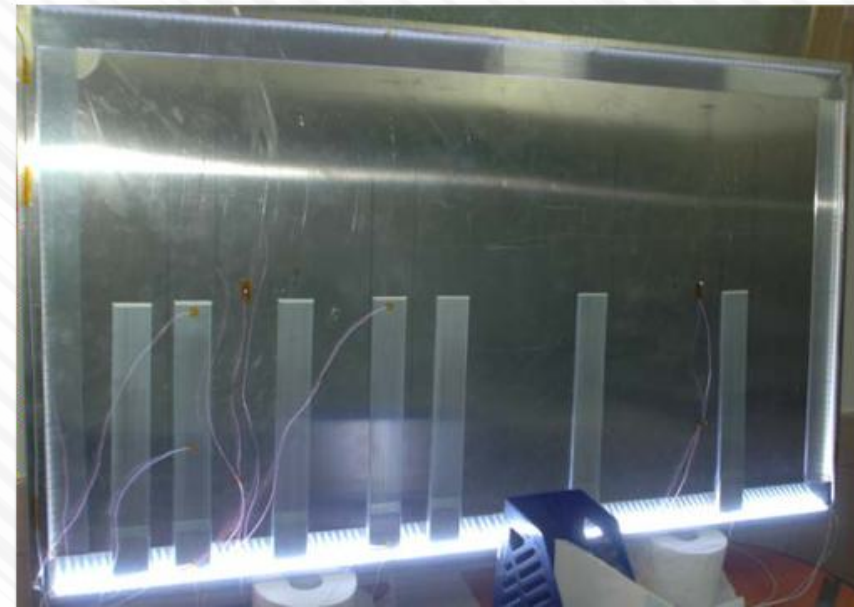

[With MG-FHP]

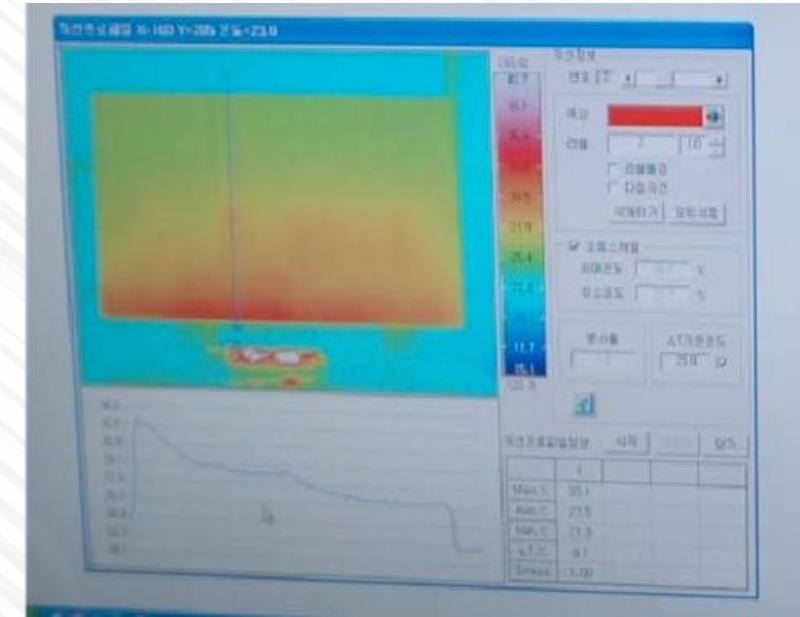

[Test result down 8-22°C]

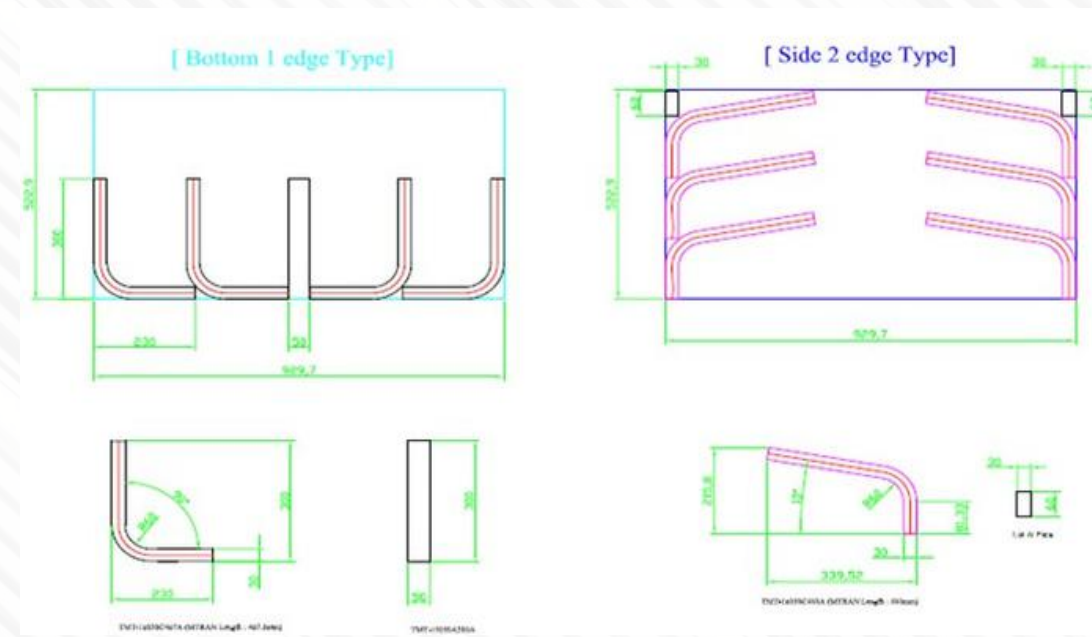
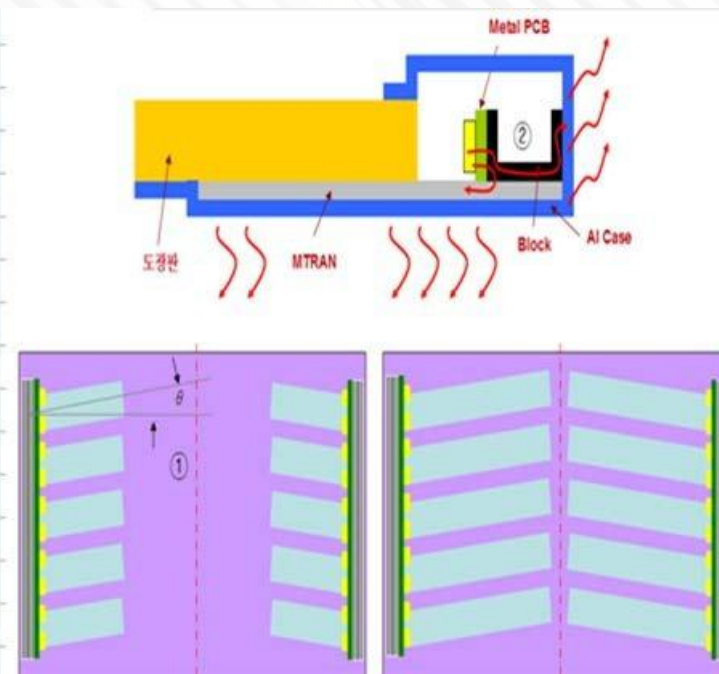

[Concept design]

# MG-FHP → APPLICATION FOR DRONE

- MG-FHP Used for drone battery-DJI

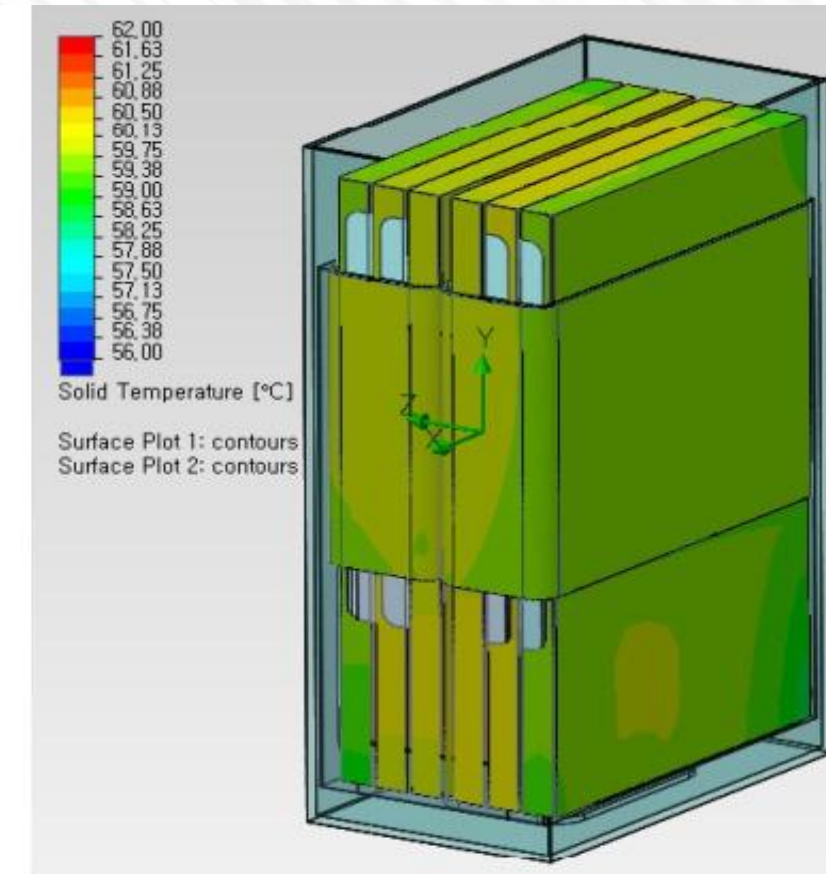
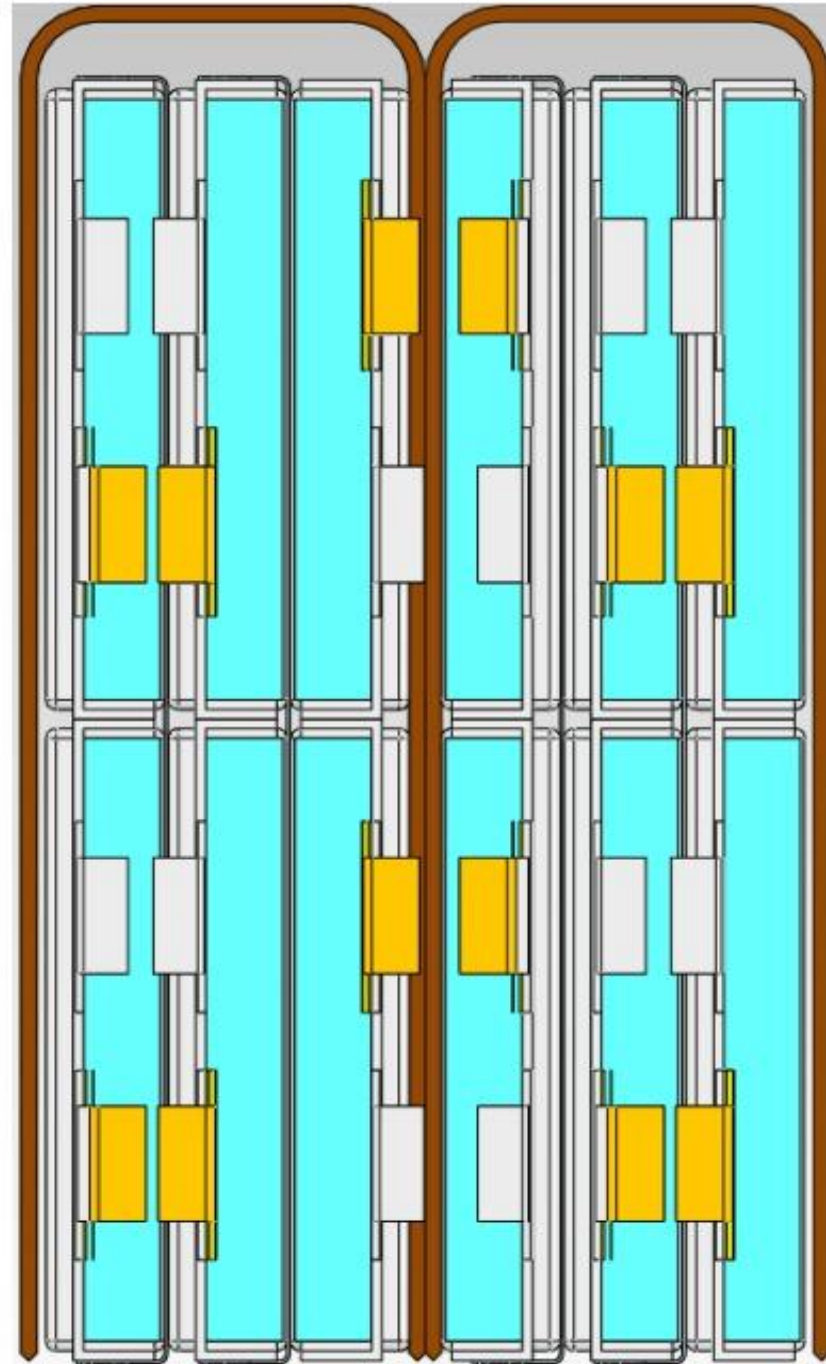
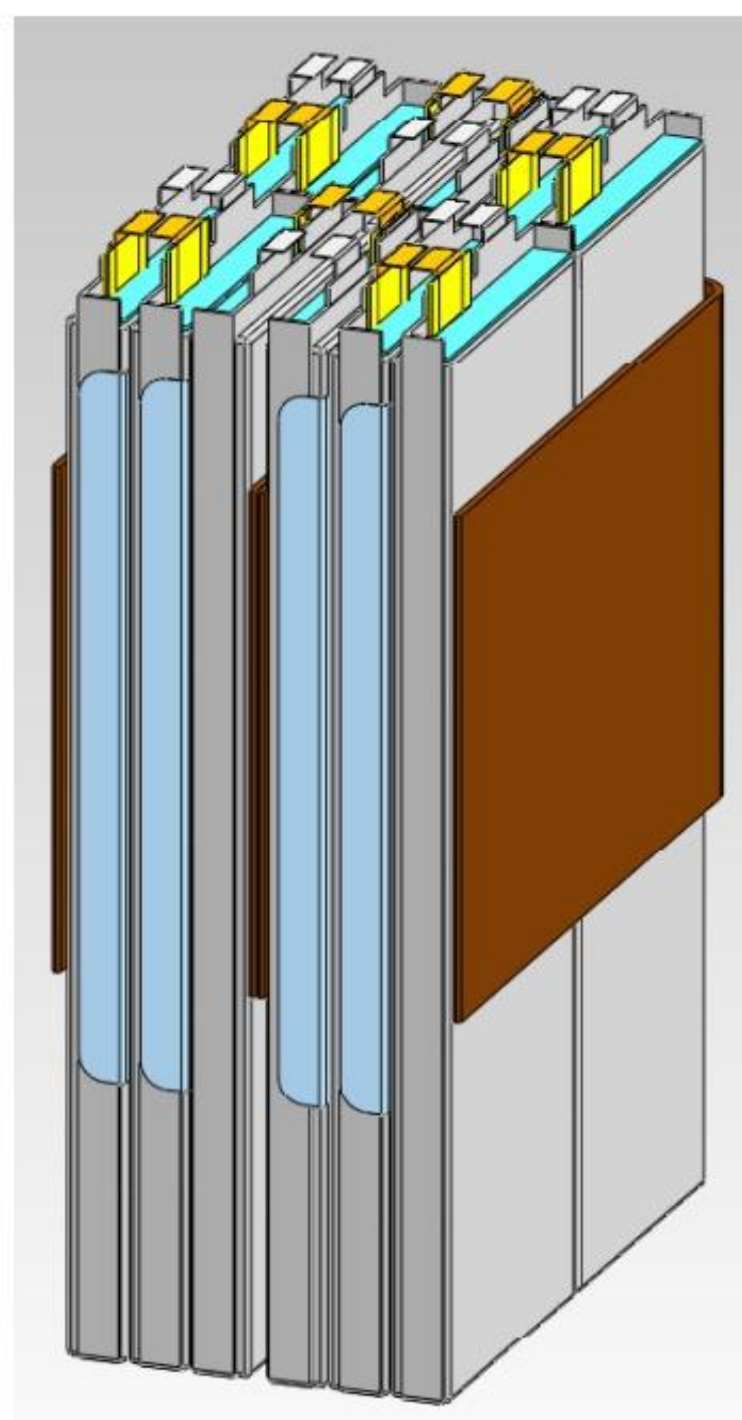

Battery No.	Min.	Max.	Avg.
1	57.98	60.26	59.70
2	58.01	60.36	60.00
3	58.45	60.39	60.11
4	58.38	60.58	60.15
5	57.86	60.57	60.25
6	58.54	60.41	59.65

# MG-FHP → APPLICATION FOR 5G POWER STATION

## ■ MG-FHP 5G power station



- Thermal conductivity:  $>5000\text{W}/(\text{m}\cdot\text{K})$ ,
- Operating temperature:  $-40\text{-}150^{\circ}\text{C}$ , temperature difference  $<2^{\circ}\text{C}$
- The working liquid does not freeze, low ignition temperature
- Connection: nickel-plated tin welding, epoxy resin bonding, brazing
- Surface treatment: nickel plating/oxidation/spraying

# MG-FHP → APPLICATION FOR IGBT

- MG-FHP Module for IGBT, Up to 2000watt

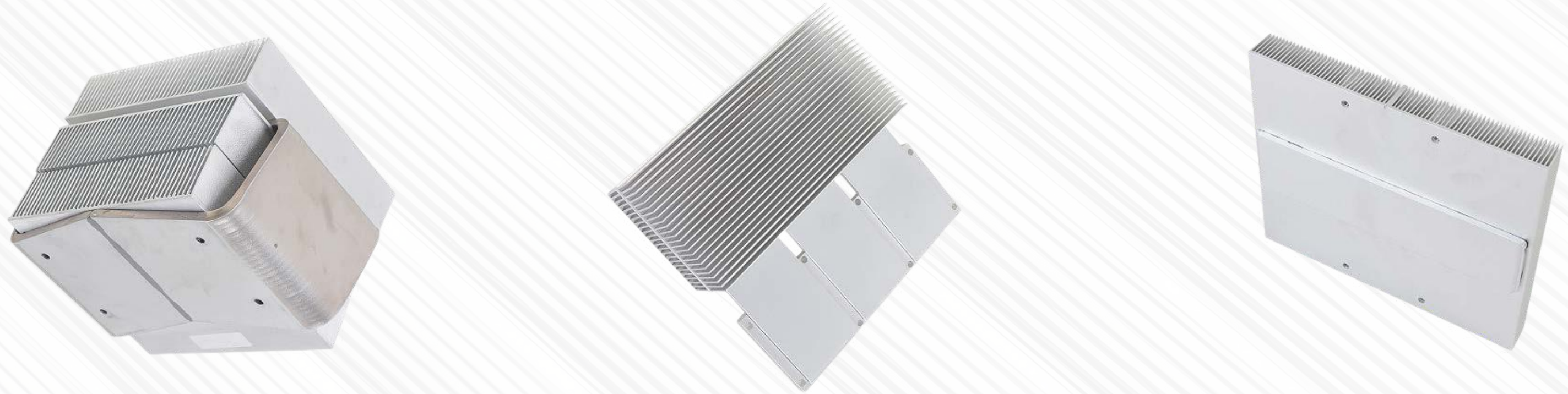

- Thermal conductivity:  $>5000\text{W}/(\text{m}\cdot\text{K})$ ,
- Operating temperature:  $-40\text{-}190^\circ\text{C}$ , temperature difference  $<2^\circ\text{C}$
- The working liquid does not freeze, low ignition temperature
- Maximum temperature:  $>190^\circ\text{C}$
- Connection: nickel-plated tin welding, epoxy resin bonding, brazing Surface
- treatment: nickel plating/oxidation/spraying
  
- Application: IGBT Electrical appliances/communications/industry/rail transit

